

FLAGSTAFF LIGHT DUTY WARNING WHIPS



FLAGSTAFF LIGHT DUTY WARNING WHIP INSTALLATION INSTRUCTIONS

The Flagstaff Light Duty Warning Whip consists of a repairable .30 in. diameter, 7 ft. flexible fiberglass shaft with a plastic coated mesh flag and mounting base for vehicle attachment.

MOUNTING INSTRUCTIONS

- 1) Insert Mounting Bolt (thread end up) through hole in mounting surface.
- 2) Secure Mounting Bolt using Jam Nut and tighten firmly.
- 3) Slide Compression Nut (with Compression Ring inserted) up the Fiberglass Shaft.
- 4) Insert Fiberglass Shaft through hole in Mounting Bolt.
- 5) Slide Compression Nut down Fiberglass Shaft and firmly tighten onto Mounting Bolt.

REPAIR INSTRUCTIONS

Fiberglass Whips can be repaired if snapped or broken near the base by cutting off the damaged area, sanding the cut edge of the shaft smooth, and reassembling following the instructions above.

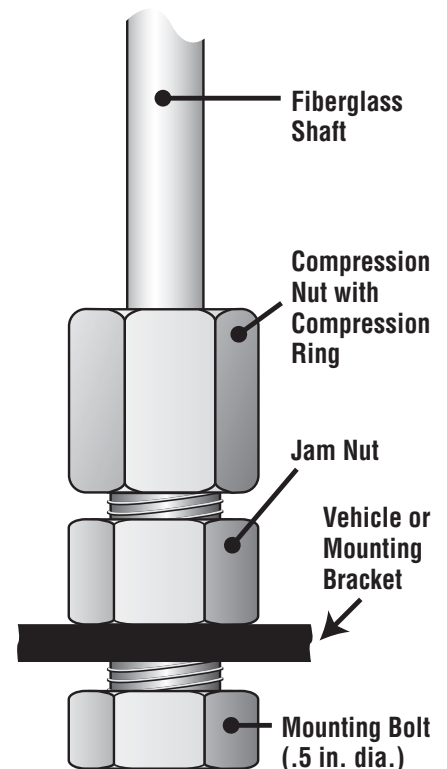

WARRANTY AND LIABILITY

LIMITED WARRANTY: Checkers guarantees the products it manufactures or sells against defects in workmanship and material for a period of one (1) year from the date of shipment or date of invoice, whichever is later. The product must be used, maintained and installed according to the instructions and procedures provided, or this warranty is void. Any alteration or modification of the product will also void this warranty. **CHECKERS' OBLIGATION UNDER THIS WARRANTY IS LIMITED TO THE REPAIR OR REPLACEMENT OF DEFECTIVE PRODUCTS.** No other warranty or remedy shall be provided. This warranty specifically does not guarantee or cover payment or reimbursement of any damages or consequential damages beyond the above.

Any claim under this warranty must be made in writing within twelve (12) months of the date of shipment or the date of invoice, whichever is later. All products returned to Checkers under this warranty must be prepaid. If it is determined that the product is defective in material and /or workmanship the repair or replacement will occur, at Checkers' option, at no charge and return freight prepaid by Checkers. All other return of product to the owner shall be at the owner's expense.

CHECKERS AND ITS AUTHORIZED AGENTS, EMPLOYEES AND REPRESENTATIVES SPECIFICALLY AND EXPRESSLY DISCLAIM ANY AND ALL OTHER WARRANTIES, INCLUDING THE WARRANTY OF FITNESS FOR A PARTICULAR PURPOSE AND/OR ANY WARRANTY OF MERCHANTABILITY WHICH MIGHT OTHERWISE BE APPLICABLE UNDER ANY STATE OR FEDERAL LAW.

LIMITED LIABILITY OF CHECKERS: Checkers and its authorized agents, distributors and representatives *do not guarantee* the performance of any Checkers product in the customer's use as the manufacturer is unable to assure proper use by the customer. Proper use by the customer is necessary for the effectiveness of the product, as well as the safety of those using same. The user is solely responsible to determine the suitability of any Checkers product for any intended use. The user assumes all risk and liability for use of any Checkers product.

User specifically acknowledges receipt of proper instructions regarding the use of the product in the original packaging and disclaims any consequential damages to person or property, damages for loss of use, lost time, loss of profit, lost income, loss of the Checkers' product itself and/or other incidental or consequential damages other than as warranted by Checkers limited warranty. User accepts the responsibility of removing from service any product that becomes worn out, unusable, unfit for intended use or defective in any way such as to make the product a potential safety hazard. Checkers is unable to undertake such obligations or responsibilities on behalf of the user as the user is in sole possession and control of the product.

© 2007 Checkers Industrial Safety Products, Inc.

Ver:FLG-LD 4/07

CHECKERS®
INDUSTRIAL SAFETY PRODUCTS, INC.

www.checkersindustrial.com

P.O. BOX 310 • LOUISVILLE, CO 80027-0310 • PH: 720-890-1187 • FAX: 720-890-1191 • TOLL FREE: 800-438-9336